

PGN44-Shapes Installation Instructions

Overview



WARNINGS

- This product must be installed in accordance with all applicable codes by a person familiar with the product.
- Each fixture must be **properly supported** during install.
- **DO NOT** join fixtures on the floor prior to lifting, or damage will occur.
- **Before beginning installation**, review our complete list of warnings by visiting www.saylite.com/warnings.

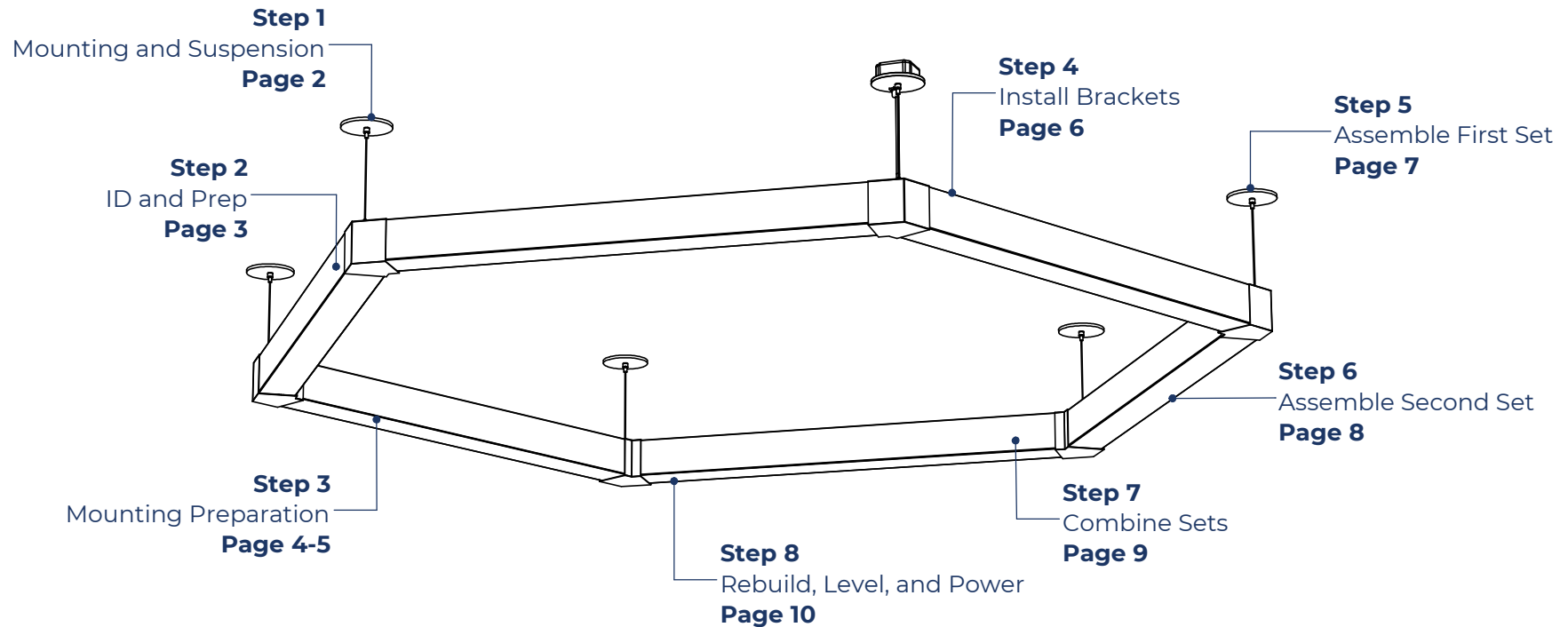

Your particular build may vary.

2020© Mobern Lighting Company | 8200 Stayton Dr., Suite 500, Jessup, MD 20794 | www.mobern.com

Form MCM - MOB-PGN44-S, V1, 09/20

PGN44-Shapes Installation Instructions

Step 1 - Mounting and Suspension



Mounting Options

Drywall or other hard surfaces - HC712 Hanging Kit*

- Install hanging kits at suspension locations.
- Ensure hanging kits are secure.
- Prepare fixture for mounting.

Other hard surfaces include: wood, sheet metal panels, steel beams, concrete or masonry. Use hardware appropriate for each surface and material type.

Suspension Locations

X = Suspension Dimensions

Refer to Assembly Drawings and building plans to determine exact mounting, suspension points, and power feed locations.

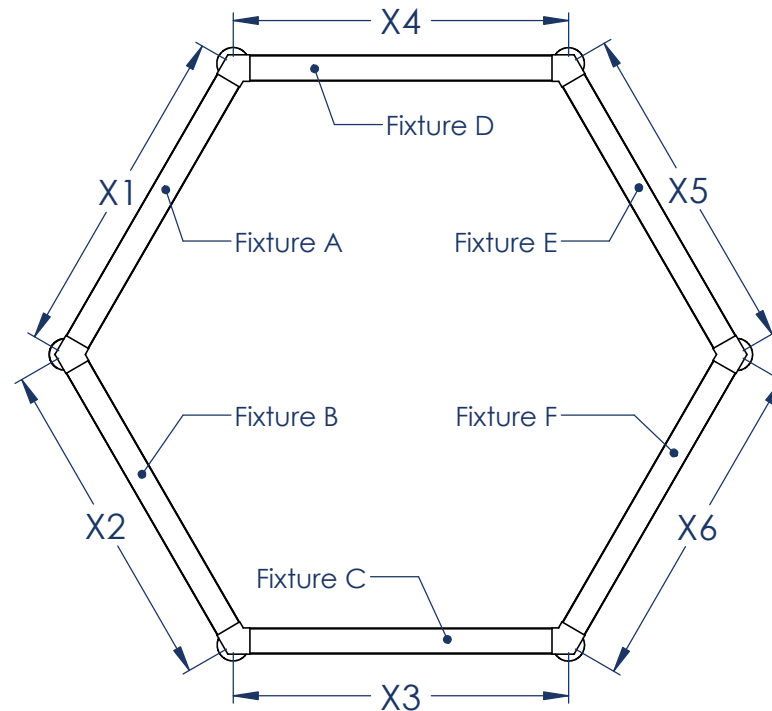

PGN44-Shapes Installation Instructions

Step 2 - Identification and Preparation



A. Identify Fixtures

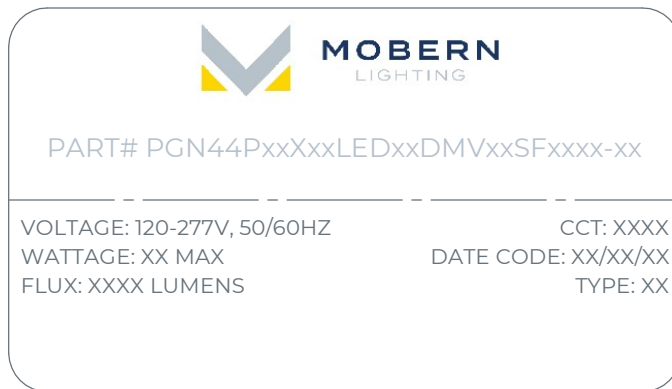

- Use labels found on the box and inside the fixture bodies to identify bodies.
- **NOTE:** Locations of labels can vary.
- Remove all fixtures from their boxes.
- Organize fixtures based on their labels at the install location.

B. Tools Needed

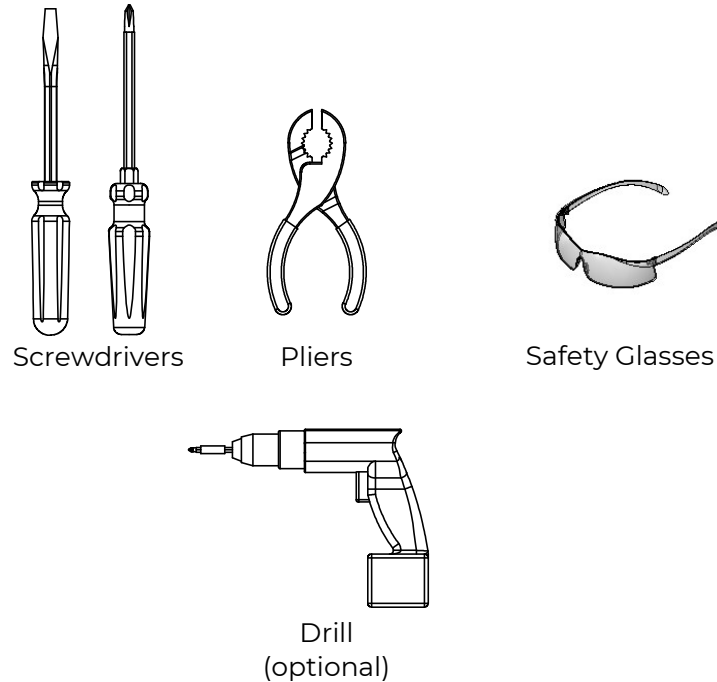

- Always use proper safety equipment when installing fixtures.
- Tools shown are recommended for standard install. Tools needed may vary based on actual install location conditions.

PGN-Shapes Installation Instructions

Step 3 - Prepare Fixtures for Mounting



A. Remove Lens

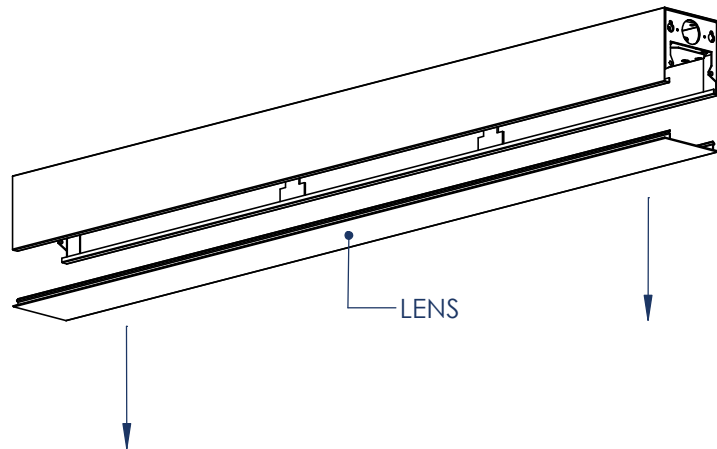

- Use the flat head screwdriver to gently pry the lens out of the fixture. Scan the QR code on this page to see a video demonstration of lens removal.

B. Determine Assembly Sets

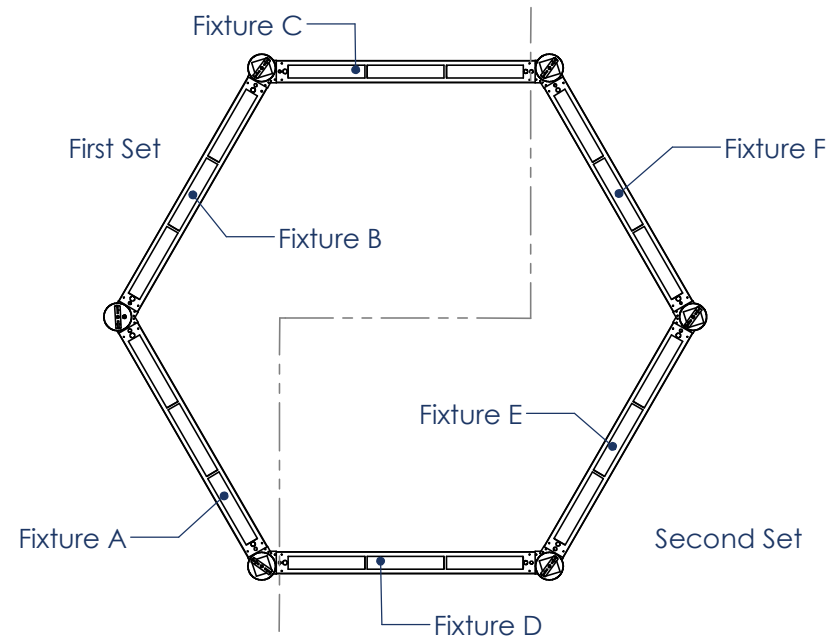

- Symmetric polygon-shaped configurations must be assembled in sets in order to ease installation.
- Asymmetric, complex configurations may need to be assembled in sets as well.
- For all configurations, consult a licensed electrician to determine assembly sets.

***NOTE:** The configuration shown is a basic example, other configurations will be divided differently.

PGN44-Shapes Installation Instructions

Step 3 - Prepare Fixtures for Mounting



A. Determine Electrical Layout

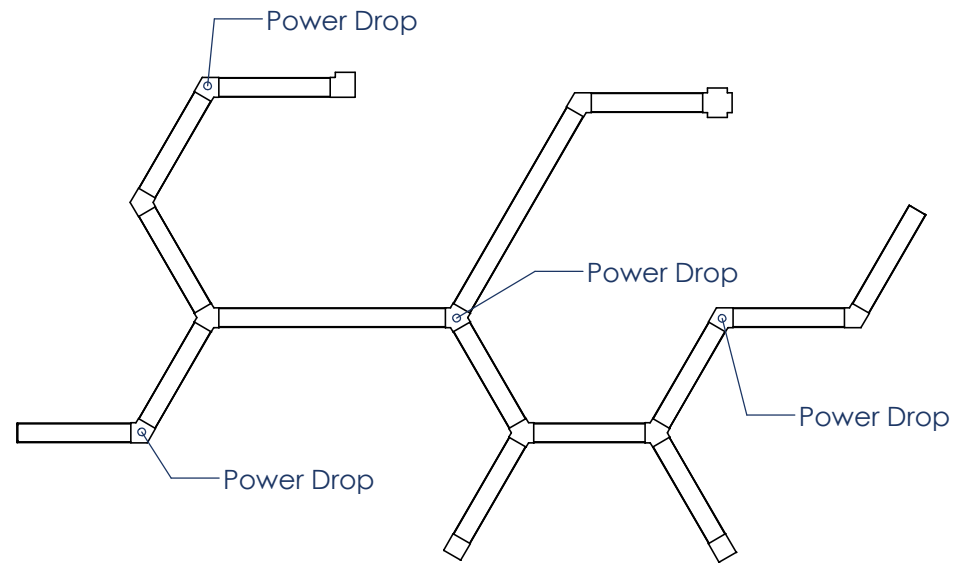
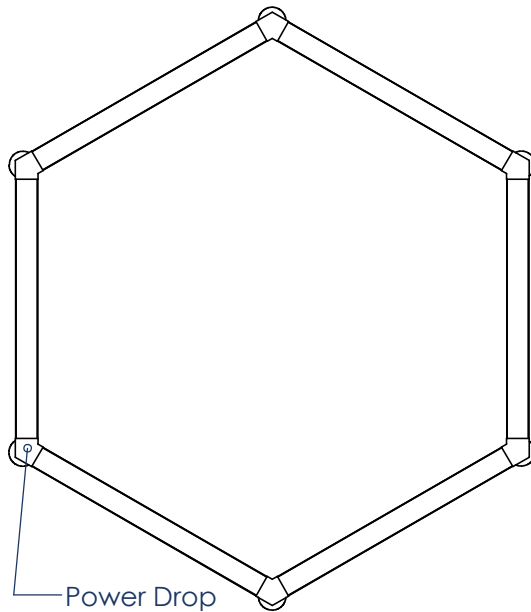

- Determine the electrical layout for each fixture assembly to be installed.
- Example Assembly A above shows how a smaller, symmetric configuration may only require one power drop. Example Assembly B shows how a larger, asymmetric, and complex configuration may require multiple power drop locations.
- **ALWAYS** consult a licensed electrician to determine best possible electrical layout for your unique configuration. The location and number of power drops will vary between configurations and should be determined prior to installing any fixtures.

PGN44-Shapes Installation Instructions

Step 4 - Install Hanging Brackets



MOBERN
LIGHTING

A. Install Hanging Cables

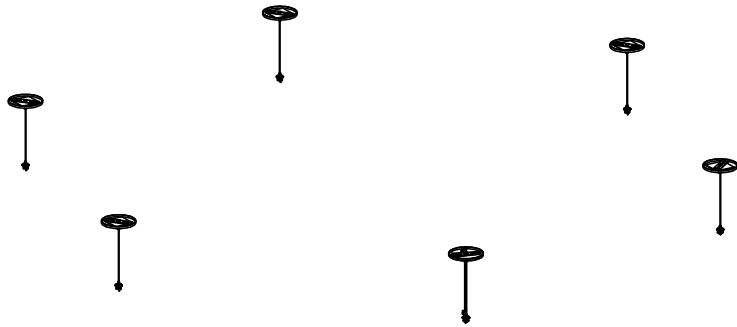

- Install hanging kits at mounting locations. Ensure all hanging kits are secure before proceeding to next step.

B. Remove Bracket Knockouts

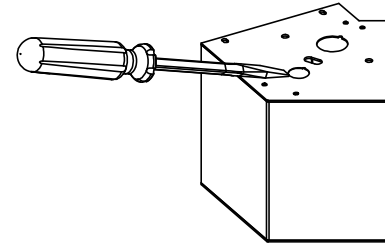

- Remove the 1/2" knockouts on each bracket with a flat head screwdriver using a gentle prying motion. Depending on power supply locations, remove the 7/8" knockout as well.

B. Attach Brackets to Hanging Cables

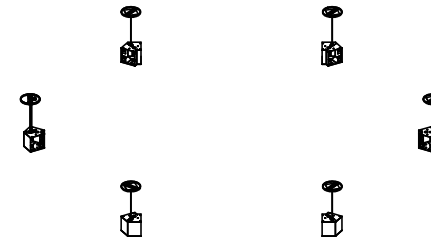

- Attach the PGN44 joiner brackets to the installed hanging kits. The procedure for attaching the brackets will vary depending on the hanging kit used.
- Consult hanging kit installation guide for more information.

***NOTE:** Depending on the hanging kit used for installation, this sub step may not be necessary. Consult your hanging kit installation guide for more information on installation and fixture attachment procedures.

PGN44-Shapes Installation Instructions

Step 5 - Assemble Fixtures A Thru C



A. Insert Fixtures

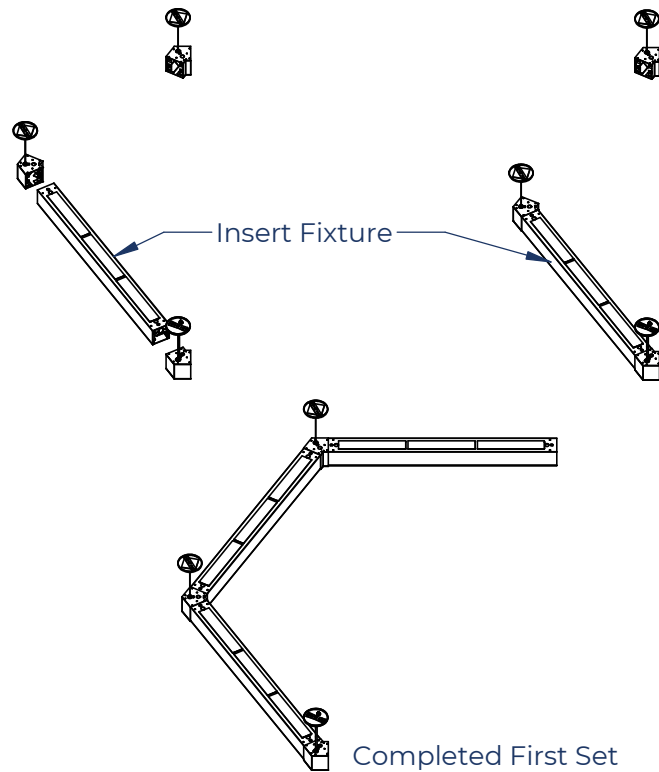

- With brackets installed, insert one fixture at a time into brackets. Join fixtures before inserting into brackets. Secure each fixture to bracket after insertion.
- Repeat sub-steps A thru C until all three fixtures in First Assembly Set are installed (see "Completed First Set" above).

B. Connect Fixtures

Hanging Kit Not Shown For Clarity

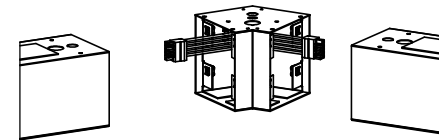

- Use provided wiring harness to connect fixtures within joiner bracket.

C. Secure Fixtures

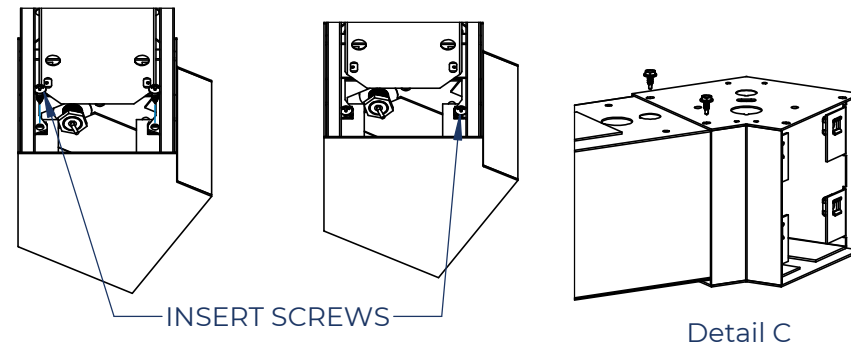

- Once fixture is inserted into bracket, use two #8 1/2" machine screws to secure fixture to bracket.
- Additional securing points can be found on the top of the bracket. Use two #8 self-tapping screws (max. 3/8" long) to secure fixture to bracket as shown in Detail C.

PGN44-Shapes Installation Instructions

Step 6 - Assemble Fixtures D Thru F



MOBERN
LIGHTING

A. Insert Fixtures

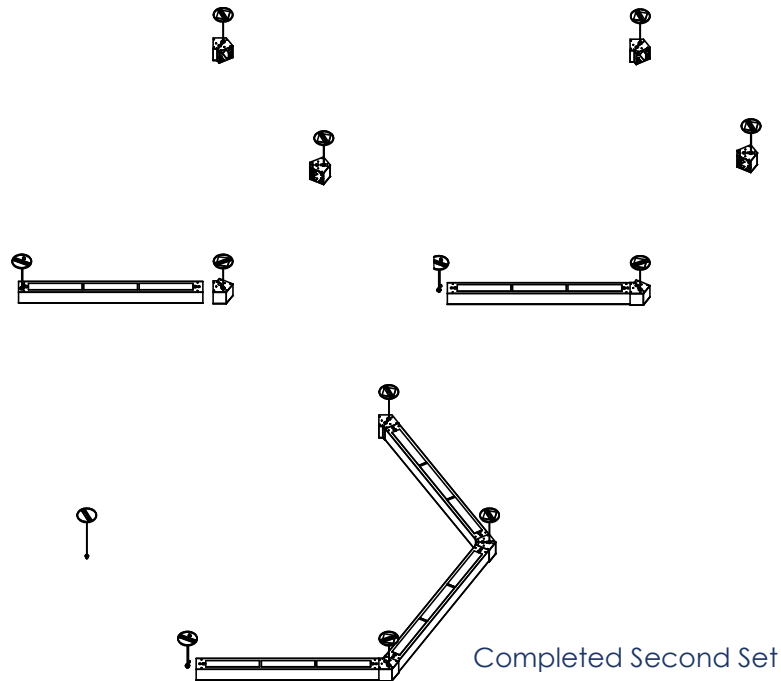

- With brackets installed, insert one fixture at a time into brackets. Join fixtures before inserting into brackets. Secure each fixture to bracket after insertion.
- Repeat sub-steps A thru C until all three fixtures in First Assembly Set are installed (see "Completed First Set" above).

B. Connect Fixtures

Hanging Kit Not Shown For Clarity

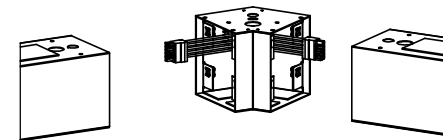

- Use provided wiring harness to connect fixtures within joiner bracket.

C. Secure Fixtures

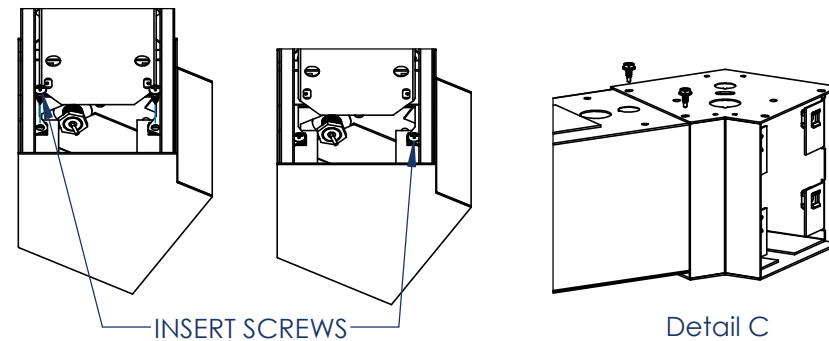

- Once fixture is inserted into bracket, use two #8 1/2" machine screws to secure fixture to bracket.
- Additional securing points can be found on the top of the bracket. Use two #8 self-tapping screws (max. 3/8" long) to secure fixture to bracket as shown in Detail C.

PGN44-Shapes Installation Instructions

Step 7 - Combine Assembly Sets



A. Insert Assembly Set Fixtures

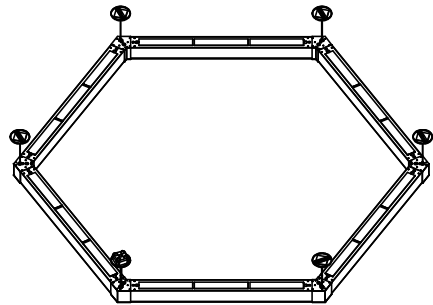
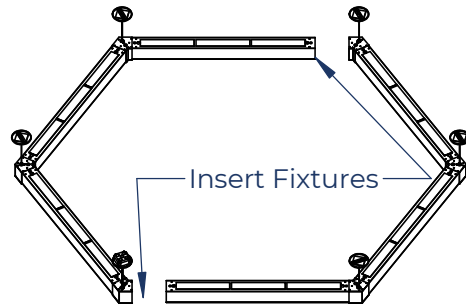

Completed Assembly

- With assembly sets installed, insert the free fixture ends into brackets.
- Connect fixtures before inserting into brackets. Secure each fixture to bracket after insertion.

B. Connect Fixtures

Hanging Kit Not Shown For Clarity

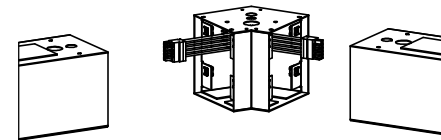

- Use provided wiring harness to connect fixtures within joiner bracket.

C. Secure Assembly Sets

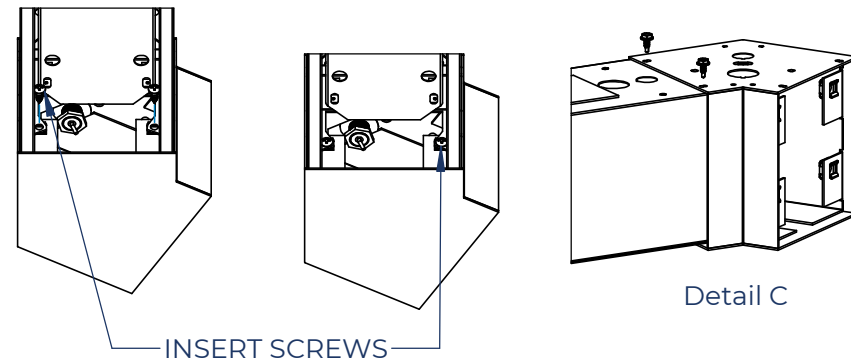

- Once fixture is inserted into bracket, use two #8 1/2" machine screws to secure fixture to bracket.
- Additional securing points can be found on the top of the bracket. Use two #8 self-tapping screws (max. 3/8" long) to secure fixture to bracket as shown in Detail C.

PGN44-Shapes Installation Instructions

Step 8 - Rebuild Fixtures and Level Assembly



MOBERN
LIGHTING

A. Replace Lenses

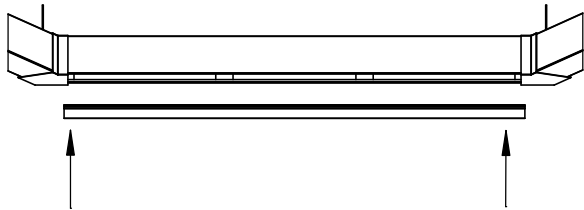

- Reinstall the lens removed in Step 3.
- First insert one side of the lens into the fixture and bracket.
- Gently bow the lens just enough to insert the opposite side into the lens and bracket.
- Ensure the lens is seated correctly in the fixture.

B. Level Assembly

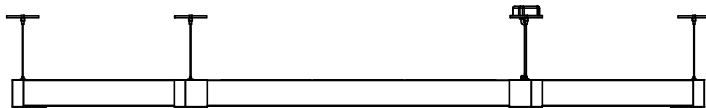

- Make final adjustments of cables if needed, ensuring fixture assembly is level.

C. Power Assembly

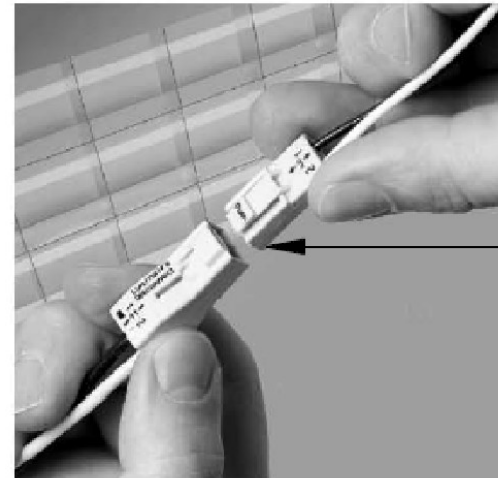

WIRING LEGEND		
BLACK	HOT	Line Voltage
WHITE	NEUTRAL	Line Voltage
GREEN	GROUND	
GRAY	DIMMING	0-10V DC
VIOLET	DIMMING	0-10V DC

- Wire fixtures to the incoming power supply using the provided quick disconnect clip as shown.
- For dimming option, refer to wiring legend above.
- Use UL approved connectors only. Follow all local, state and national codes. Repeat for all remaining fixtures.
- Fixture installation is now complete.