

APPLICATIONS

Ideal for commercial, institutional and industrial facilities where economy, appearance, and ultimate ease of installation and maintenance are desired. Also ideal when a low profile unit needs to meet limited space requirements and any space requiring back-up emergency lighting.

FEATURES & BENEFITS

- ◆ Wall mount via knockouts on the back of the housing
- ◆ Dual 120/277 voltage
- ◆ Charge rate/power 'ON' LED indicator light and push-to-test switch for mandated code compliance testing
- ◆ LVD (Low Voltage Disconnect) prevents battery from deep discharge
- ◆ Maintenance-free, rechargeable sealed lead acid battery
- ◆ Internal solid-state transfer switch automatically connects the internal battery to lamp heads for minimum 90-minute emergency illumination
- ◆ Fully automatic solid-state, two-rate charger initiates battery charging to recharge a discharged battery in 24 hours.
- ◆ Five year warranty on all electronics and housing
- ◆ Battery pro-rated for two years
- ◆ Meets UL924, NFPA 101 Life Safety Code, NEC, OSHA, Local and State Codes
- ◆ UL listed for wet locations.

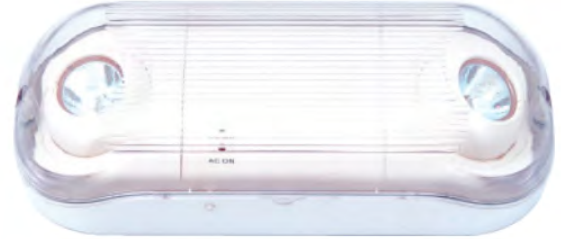

SPECIFICATIONS

Injection-molded, engineering-grade, 5VA flame retardant, high-impact resistant, thermoplastic in neutral gray or black finish. Fully-gasketed clear polycarbonate cover offers protection against wet, non-hazardous dust, corrosive atmospheres and to water spray or splashing water locations. Two fully adjustable, ultra-bright, round, 7W MR-16 halogen lamp heads with a fully gasketed enclosure and clear polycarbonate lens cover.

ORDERING DATA

EXAMPLE: MEBEMMR16WPHTR

MEBEMMR16WP

Series	Color	Options
MEBEMMR16WP	Blank Grey BK Black	HTR Internal Heater USA Assembled in USA LED LED Lamps

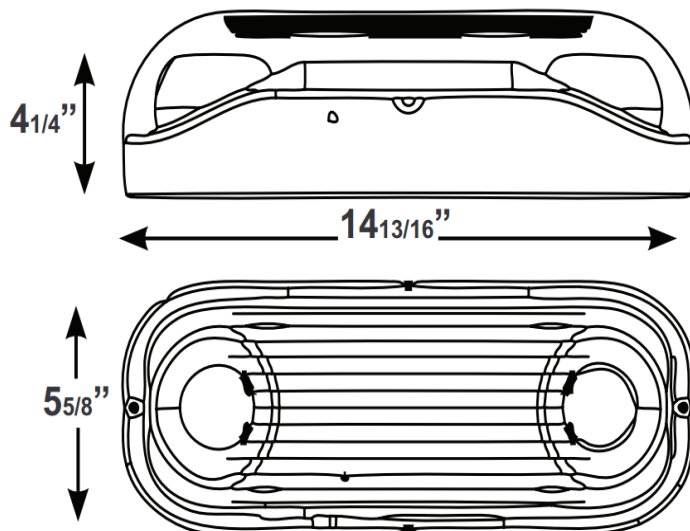

Dimensions and specifications subject to change without notice.

CAT#	
JOB NAME	
TYPE	